



Desiccant Breathers

Model DB

- Construction: ABS plastic & impact-modified acrylic
- Removes corrosive water vapor
- Operating temp. range: -20° F to +200° F (-28° C to +93° C)
- Four standard sizes (3" to 10")
- Bi-directional air flow
- Silica gel turns from gold to green when maximum absorption is reached
- Dual filter system with anti-static guard
- Solid contaminant filtration surface area 20.6 in² (133 cm²)
- Silica gel absorbs up to 40% of its weight in water
- Resistant to alkalis, hydrocarbons, non-oxidizing acids, salt water, and synthetic oils

Option

- Activated charcoal media (consult factory)
- 5 PSI Maximum Operating Pressure

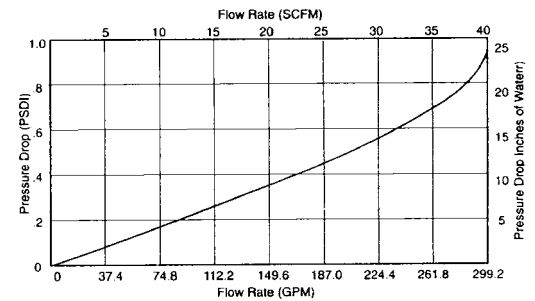
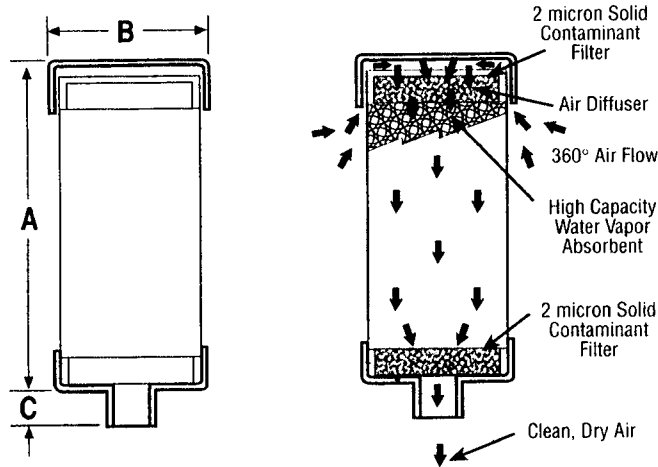

Dimensional Detail

MODEL NO.	BREATHER CONNECTOR	MICRON RATING	CAPACITIES		MAX. H2O CAPACITY		A		B		C	
			CFM	GPM	FL. OZ	CUP	IN.	CM.	IN.	CM.	IN.	CM.
DB-03	1 5/16" O.D. Tube	2	35	262	3.1	.4	3.5"	9.0	5"	12.8	1.25"	3.2
DB-05	1 5/16" O.D. Tube	2	35	262	6.2	.8	5.0"	12.8	5"	12.8	1.25"	3.2
DB-08	1 5/16" O.D. Tube	2	35	262	13.9	1.7	8.0"	20.5	5"	12.8	1.25"	3.2
DB-10	2" NPT	2	100	750	18.5	2.3	10.0"	25.4	5"	12.8	1.6"	4.1

Note: Connector for sizes 3, 5 and 8 1 5/16" O.D. tube is designed to interface fit with an adapter on new installations - adapters need not be replaced.
Hex diameter on DB-10 is 2.56"

DB-FA
Flange Adapter

DB-R1, R2, R3
Threaded Adapter

DB-BA
Bayonet Adapter

DB-C1, C2
Spin-on Adapter

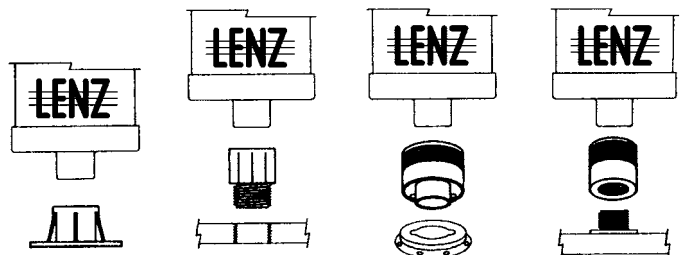

MODEL NO.	DESCRIPTION
DB-BA	Bayonet Adapter
DB-C1	1"-12 UNF Female to Female Coupling
DB-C2	1 1/2"-16 UNF Female to Female Coupling
DB-FA	Flange Adapter
DB-R1	1" NPT Pipe Thread Reducer
DB-R2	3/4" NPT Pipe Thread Reducer
DB-R3	1/2" NPT Pipe Thread Reducer